

**ZAGI-LE**

## **1999 Combat Wing**

Wing Span	48"
Wing Area	2.83 SqFt
Airfoil	Zagi 99
Weight	18/23 oz
Loading	7 oz/sq.ft
Radio	2 channel or mixer
Speed Range	Wind: 6 to 45 mph



Visit: [ZAGI.com](http://ZAGI.com) Email: [Zod@Zagi.com](mailto:Zod@Zagi.com) Voice: (310) 301-1614 Fax: (310) 822-7695

**Trick R/C Products LLC 938 Victoria Ave. Venice, California 90291**

## **INTRODUCTION**

Read the instructions first to get an overview of the process.

For rough duty—combat or bad landing areas—refer to the Alternate Building procedures after Wing Assembly, Step 1. For Standard Building skip Alternate Building procedures on pages 4 and 5.

The Recommendations provide some overall hints and lessons learned in constructing prototypes. Read this section first.

## **ZAGI-LE COMBAT WING**

### **RECOMMENDATIONS**

The square pack 5/700 mAh battery should not be placed closer than 2 ½” from the nose.

There is plenty of room for standard servos and a 5/700 mAh battery pack.

Cut the receiver bay deep enough to stuff extra servo wires and switch plugs underneath. The receiver can even be installed face down. Do the same with mixer if required.

Do not use solvent base-paint on either types of foam.

Do not use Shoe Goo or any other Goop glue on the Styrofoam part of the Zagi.

Lightly spray the entire wing with 3M #77 Spray Adhesive before you begin covering in Step 2. If a substitute adhesive is selected, test spray a patch on the beds before spraying the cores.

Do not cut into any part of the leading edge foam for the radio installation or nose weight.

MonoKote or other iron-on materials can be used instead of tape on both types of foam. Use a sock over the iron. Again, test a patch on the beds first.

For the first flight, the recommended CG (center of gravity) is 7 inches back from the nose. Conditions and pilot skill level will ultimately determine where to balance the Zagi. For aerobatic performance adjust the CG back to 7 ¼" to 7 ½". This will increase the speed and improve inverted flight stability.

# ZAGI-LE COMBAT WING

---

## The ZAGI-LE COMBAT WING Kit contents:

- 2 Expanded polypropylene (EPP) leading edges laminated to 2# white foam wing panels and beds
- 2 Pre-cut balsa elevons
- 1 Roll 2.4 mil poly tape
- 2 Control horns with 4 screws
- 2 Threaded 2 X 56 push rods
- 2 Threaded 2 X 56 clevises
- 1 1 1/2" X 2" X 8" EPP Foam block for repair and reinforcement
- 2 Die-cut plastic winglets

## Tools and materials needed:

- 90 degree square
- Sanding block
- 150 to 320 grit sandpaper
- X-Acto knife or Dremmel
- Round pencil or ball-point pen
- 5 Minute Epoxy
- Spray adhesive (3M #77 or similar)
- 2 oz. lead ball (fishing weight)
- 2" Fiber filament strapping tape

## Equipment Needed:

- Minimum 2 channel radio w/mixing function
- Standard receiver
- 2 Standard Servos (approx 1.7 oz/48.5 g)

For technical support call 310-827-2288

## STEP 1 WING ASSEMBLY

Lightly block sand the wing panels (cores) with #320 paper and round the leading edge (LE). (See Figure 1)

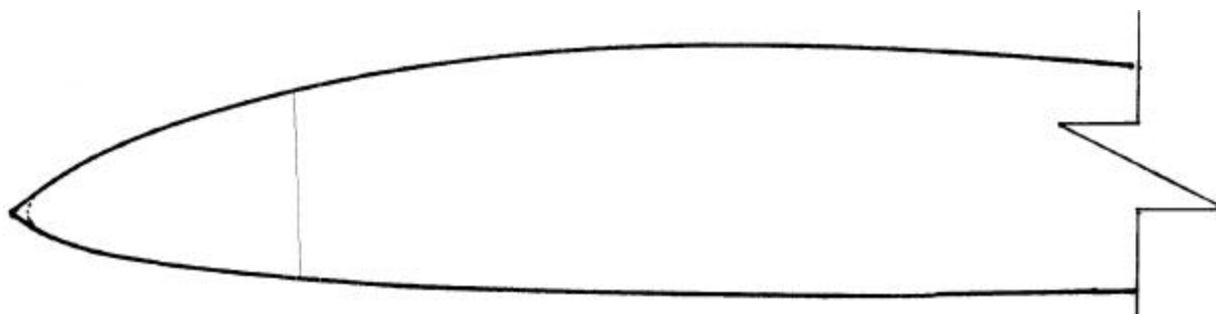
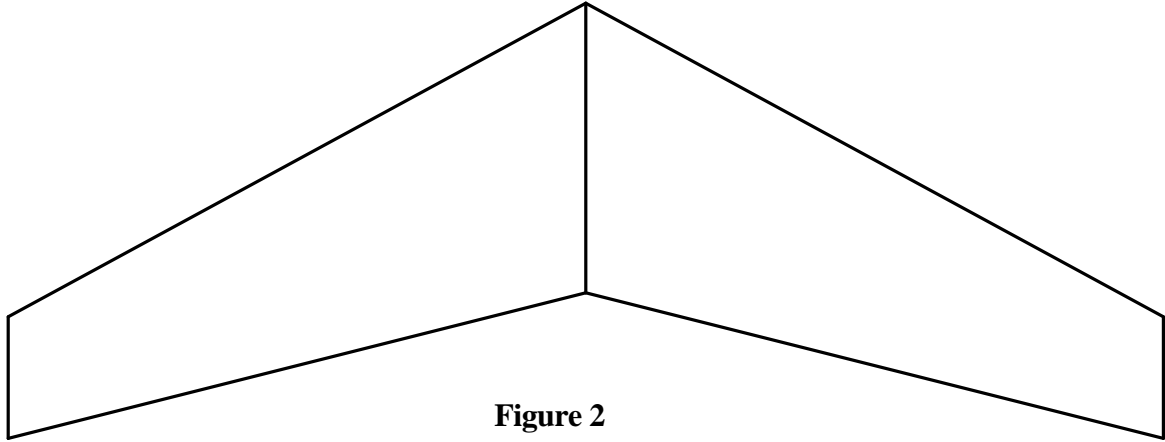

Figure 1

Layout the bottom beds on a flat surface. Epoxy or tape them together. Repeat for top beds.

When the epoxy cures align the cores together on the bottom bed and epoxy them together using beds as a jig. Put a piece of clear wrap or wax paper between the beds and the cores to prevent sticking. (See Figure 2)

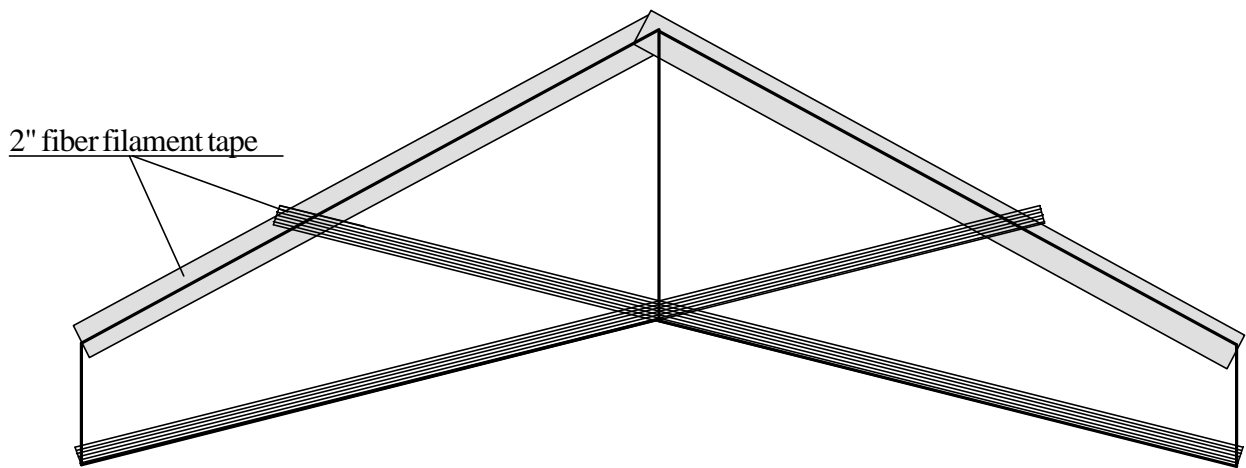

**Figure 2**

*The ZAGI-LE should be sprayed and covered with tape before any holes are cut for radio installation. Most of the colors are transparent enough to see the servo cut-out marks through the tape. If a dark color tape is used, make some small impressions with a pencil at the corners of the servo cut-out marks.*

Vacuum the dust from the cores, beds and the work bench.

Lay the wing in the beds top-side up. Apply a light coat of 3M #77 spray adhesive to cover the top of the entire wing. Allow the adhesive spray to dry at least 30 minutes. Repeat this procedure on the other side. Lay the wing top side up in the bottom beds. Apply a strip of fiber filament tape along the trailing edge from the wing tip across to the opposite leading edge. For rough terrain or extreme combat duty, wrap the leading edge with one strip of 2" fiber tape. (See Figure 3)



**Figure 3**

## Alternate Building Procedures for a Reinforced Nose

A reinforced nose can be made by using a piece of the 1 ½" X 2" X 8" EPP foam blocks provided in the kit.

Measure 1 ½" from the back of the EPP foam leading edge. Use the 1 ½" side of the foam block as a guide to make a line span-wise. (See **Figure Alt.1**)

With the block still in place transfer the sweep angle of the nose triangle onto the EPP foam.

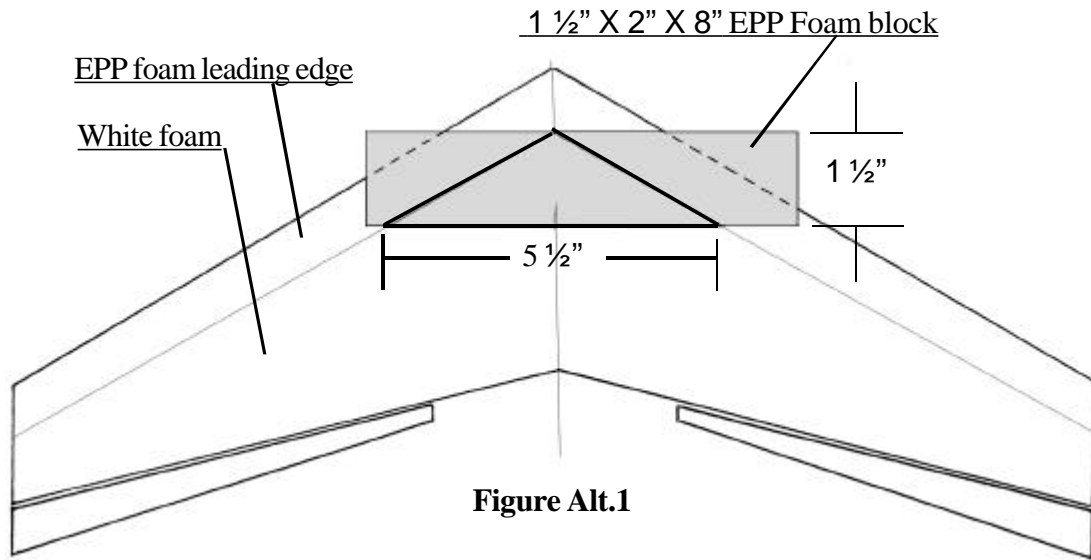

Remove the white foam. Be careful to make a flat square gluing surface for the bulkhead. (See **Figure Alt.2**)

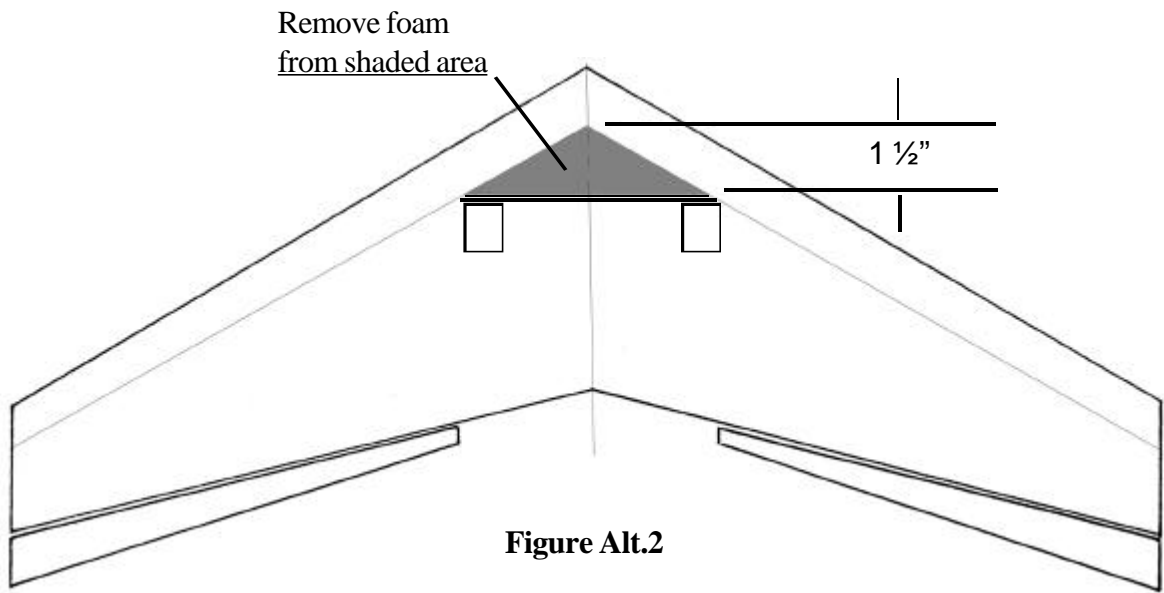

## Alternate Building Procedure for a Reinforced Nose, Part 2

Make a bulkhead to fit against the white foam with a piece of plywood 1/8" thick by 5 1/2" long by 1 1/2" high. (plywood is not included in the kit)

Fit the plywood bulkhead in place. Shape it flush at both the top and bottom of the wing.  
Epoxy it in place.

Cut the EPP foam to a snug fit. (EPP foam cuts easily with a sharp kitchen knife).

Trim the EPP foam to match the nose contour.

Lay the wing in the beds and epoxy the EPP reinforcement foam into place.

End **Alternate Building Procedures**, proceed through Steps 2, 3 and 4.

IN STEP 5, RADIO INSTALLATION, refer to this page for Receiver and Battery Installation

Center the battery and receiver directly behind the plywood bulkhead and trace the outline. Remove enough foam so that the radio gear fits snug and flush. Cut the receiver bay 1/8" deeper than receiver thickness. Stuff the extra servo and switch harness under the receiver.

Proceed through Steps 6 and 7

IN STEP 8, BALANCING, refer to this page for nose weight location

Install the nose weight in the EPP foam against the plywood bulkhead opposite the receiver (RX).  
(See **Figure Alt. 3**)

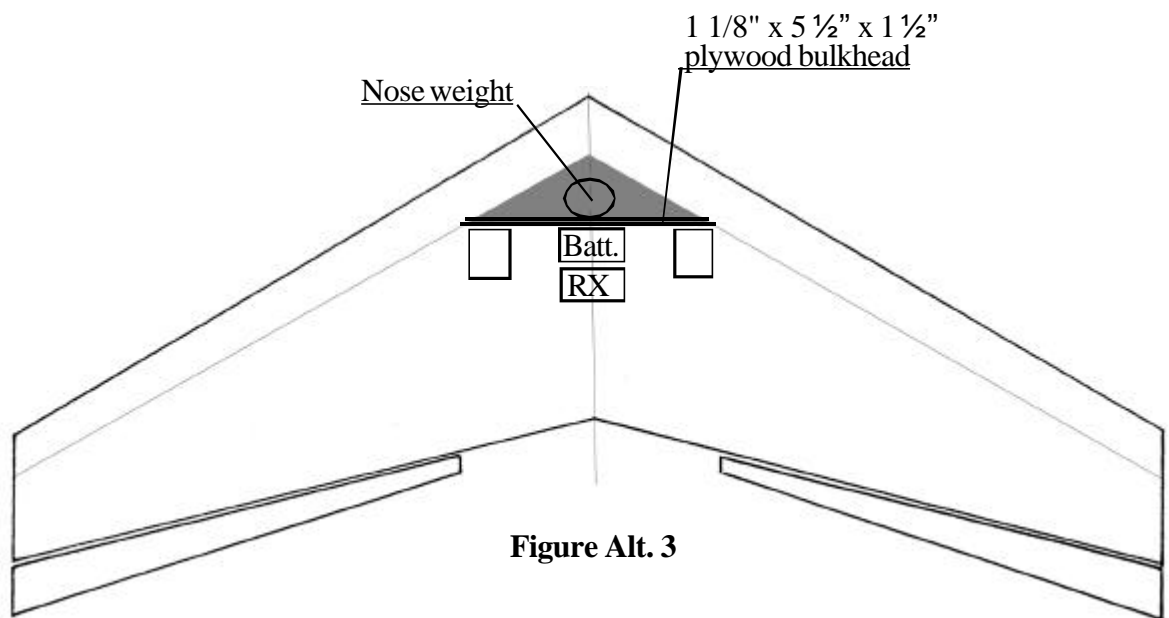

Figure Alt. 3

## STEP 2 COVERING (Resume Standard Building Steps)

Start the tape covering at the trailing edge (TE) of the wing by wrapping a strip of tape around the TE being careful to follow the shape. Cut the tape to length and position. Apply evenly along the surface. Stretching the tape may cause the wing to warp.

Working from the TE forward, lay strips of tape from tip to **at least 4 inches past center**. (See Figure 4)

Overlap the tape only 1/4" all the from the center to the tip.

Cut the tape at an angle at the LE.

Place the wing in the top bed and repeat the taping procedure working from TE forward to the LE.

Finish the leading edge with a single spanwise piece of tape wrapped around the LE. (See Figure 5)

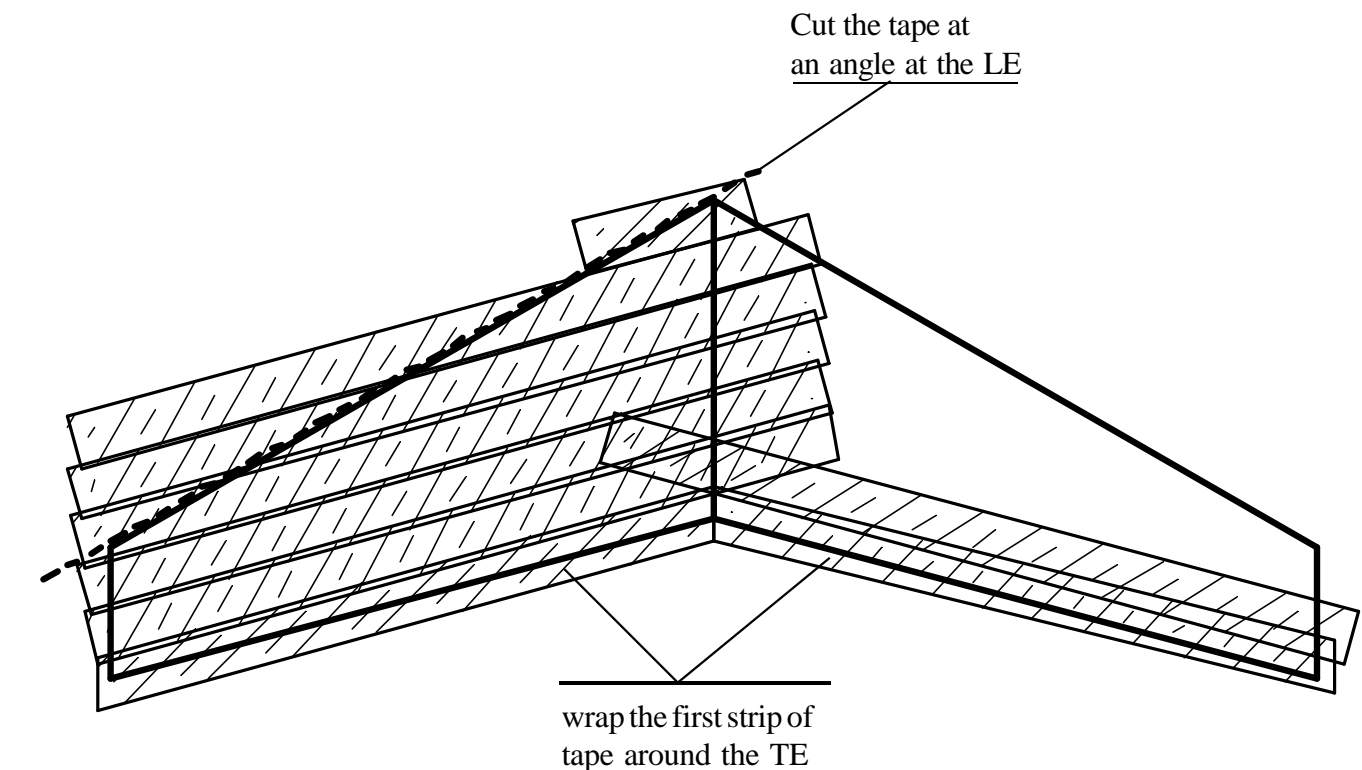

Figure 4

wrap the leading edge with a single spanwise piece of tape

Overlap the tape 1/4"

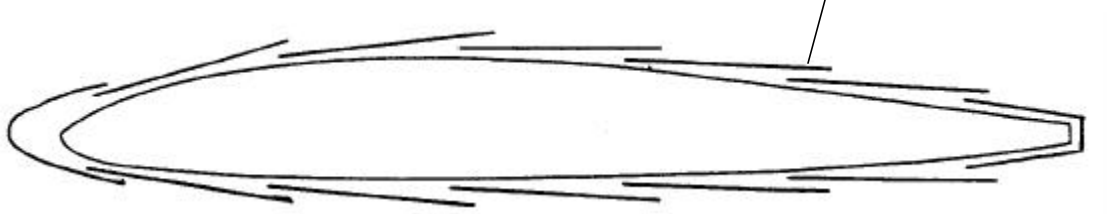

Figure 5

### STEP 3 ELEVON ASSEMBLY

Hold the elevons together and sand them until they are identical.

Sand a 45 degree angle into the front of the elevon then completely cover the elevons with tape, making sure the edges are wrapped. (See Figure 6)

Position the elevon on the trailing edge of the wing with small pieces of tape. Trim the ends to match the wing tips. (See Figure 7)

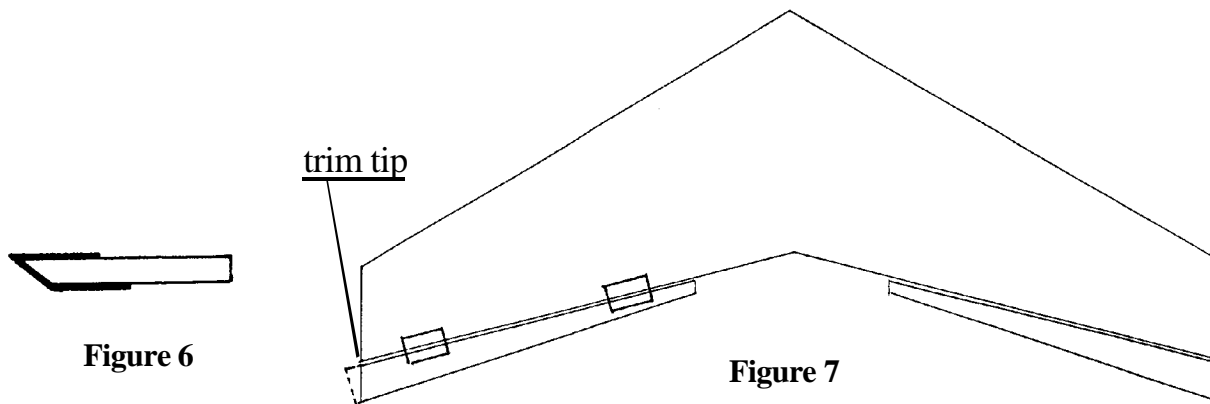

Make a tape hinge the full length of each elevon. (See Figure 8)

Swing the elevon to the top of the wing and lay flat. Use a small piece of tape to hold it there.

Complete the hinge with another full length strip on the bottom as shown. (See Figure 9)

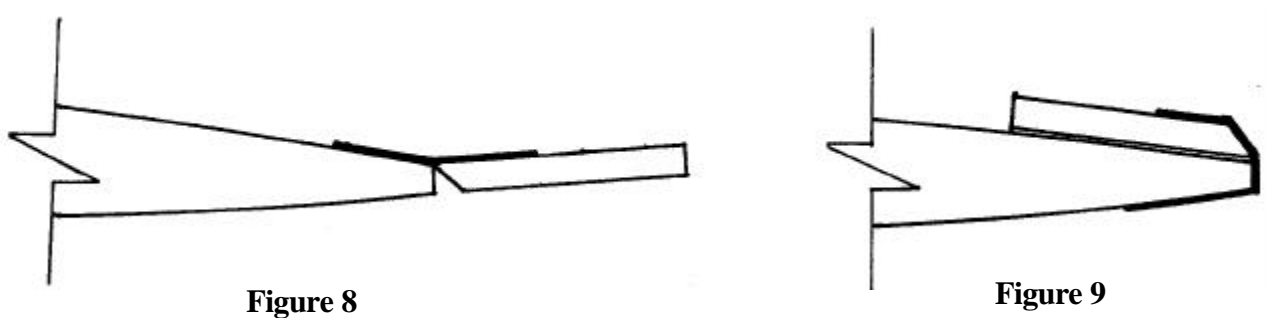

## STEP 4 SERVO INSTALLATION

**Note: It's better to use standard servos and a 500 mAh square pack battery. If smaller components are used compensate with extra nose weight.**

Servo positions are marked on the top of the wing panels.

The wing thickness will accommodate standard servos.

Servo control arms should be straight up facing outboard—toward wing tips.

Cut or router the servo holes to a tight squeaky fit so that no glue is necessary.

Cut and fit often until the servo is flush with the wing contour. Use wood shims if the servos have any play. Tape the servos in place. (See Figure 10)

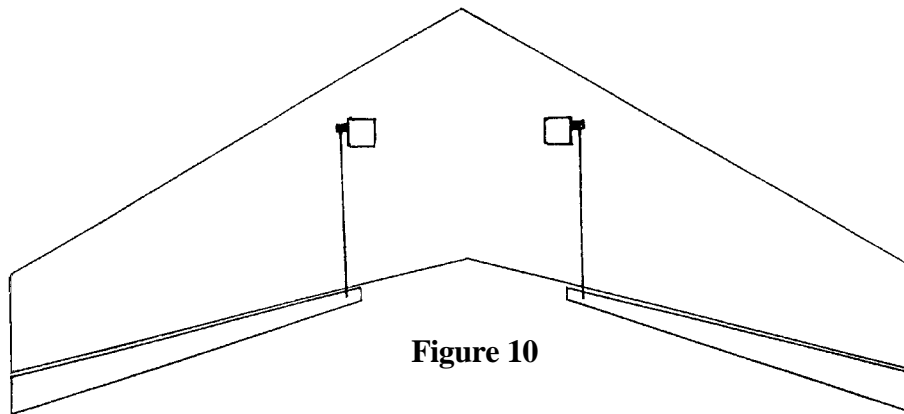

Figure 10

Attach the control rods to the 3rd hole of the long servo control arms.

Install the control horns on the elevons.

Attach the clevises to the control horns.

Attach control rods to the servos with a Z-bend.

Make a 10 degree bend in the control rods 1 inch behind servo to prevent binding. (See Figure 11)

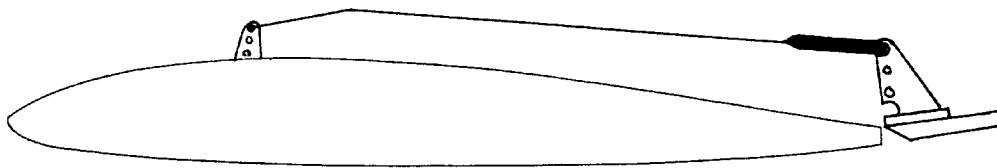

Figure 11

**STEP 5**

**RADIO INSTALLATION (See Figure 12)**

Place the battery 2 1/2" back from the nose.

Outline the exact shape of the battery, then cut and remove the foam until battery is flush.

Place the nose weight 2" from the nose and trace its shape. Cut and remove the foam until the nose weight fits flush. Start with 3 ounces.

Center the receiver 3/4" behind the battery.

Cut the receiver bay 1/8" deeper than the receiver thickness. (For electronic mixers, cut the receiver bay 3/8" deeper so that the mixer fits under the receiver.)

Stuff the extra servo wires and switch harness under the receiver.

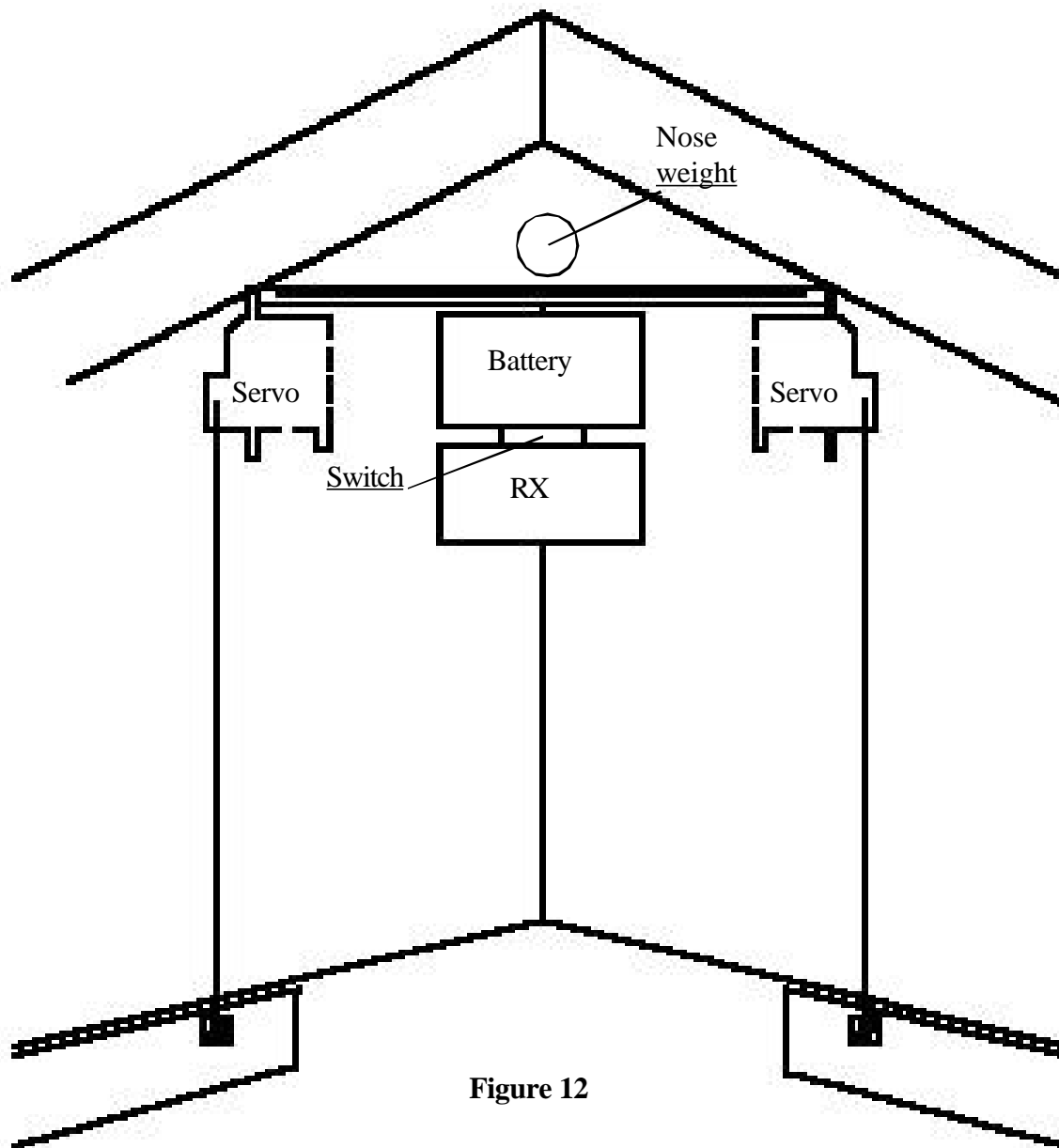

**Figure 12**

## STEP 6 COMPLETING RADIO INSTALLATION

Cut slots in the foam 1/8" deep between the receiver and servos for servo wires.

Cut a slot in the foam 1/8" deep the full length of a panel for the antenna.

Tape all components flush, in place. (See Figure 13)

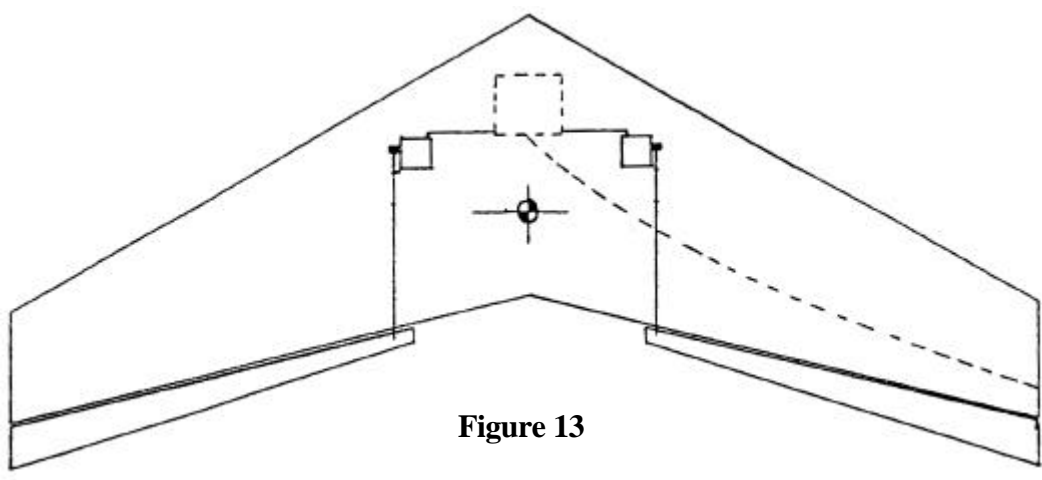

Figure 13

## STEP 7 TRIM AND THROW

Set the elevon neutral setting by laying a straight edge under the wing at the trailing edge. The elevons should appear to have a few degrees of reflex. (up elevator) (See Figure 14)

Move the transmitter aileron stick from full right to full left (not up or down).

The elevon throw should be 3/8" in each direction measured 1" from the tip (no differential)

.When moving the elevator stick full up to full down, the throw should be 3/8" in each direction.

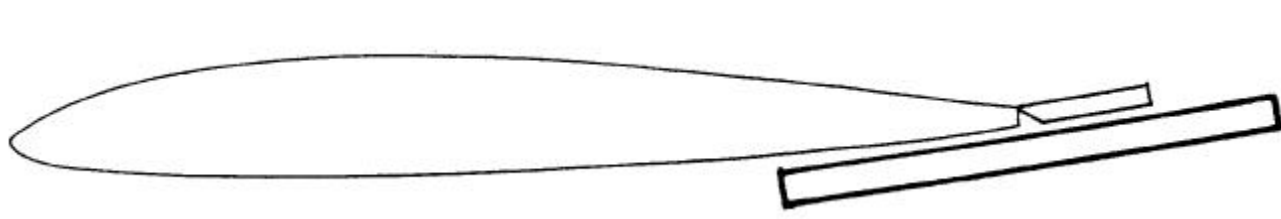
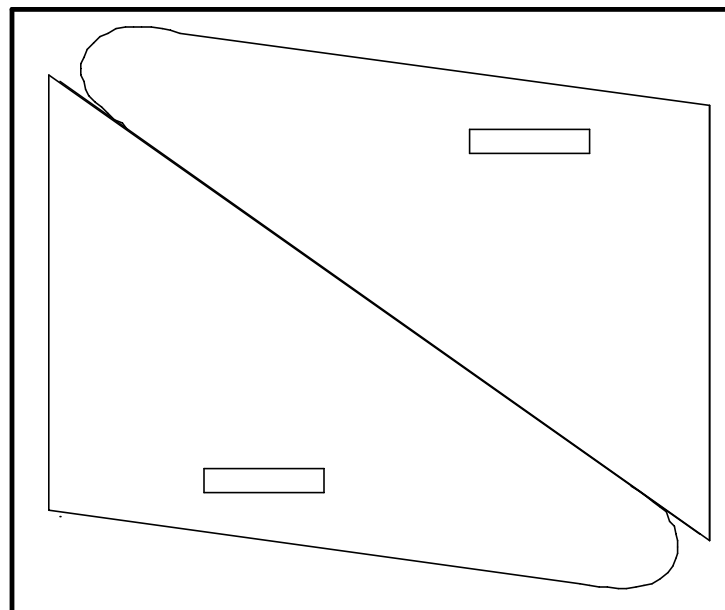

Figure 14

Punch-out and separate the two nested clear winglets. Punch-out the 1 1/4" x 1/4" slot in the winglet. (See **Figure 15**)

Put a piece of fiber filament tape through the slot to the top of the wing and wrap it around to the bottom of the wing. Add two more pieces of tape to secure the winglet in place. Make sure that the elevon will not bind against the winglet as it moves. (See **Figure 16**)

**The winglets are at the very back of the airframe. The tape method of fastening is both light and strong. If a different winglet fastening system is preferred, keep the weight down to the weight of four short strips of tape.**



**Figure 15**

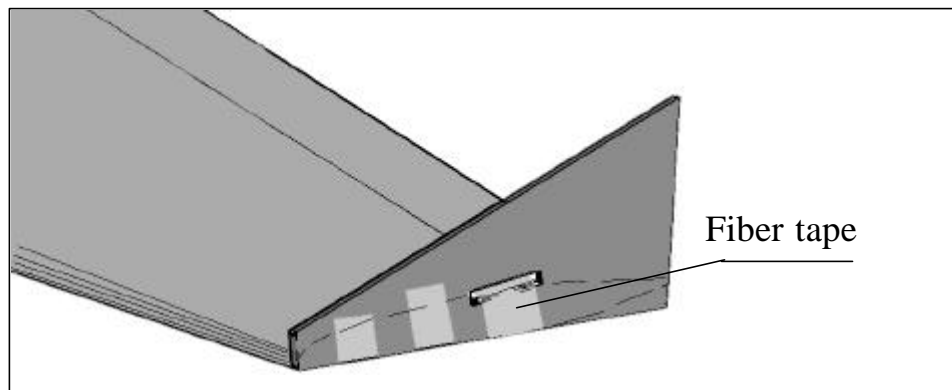
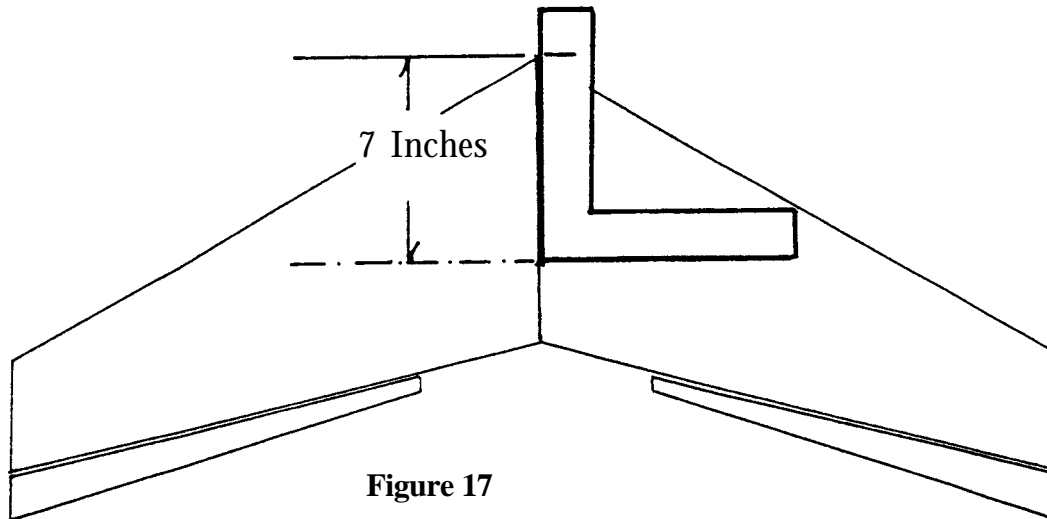

**Figure 16**

## STEP 9 BALANCING CENTER OF GRAVITY (CG)

### BALANCE IS THE MOST IMPORTANT STEP

Lay wing bottom-side-up. Using a square, mark the CG by making a line perpendicular to the center line 7" back from the nose on both panels. (See Figure 17)



Tape a round pencil or ball-point pen directly over the CG line. (See Figure 18)

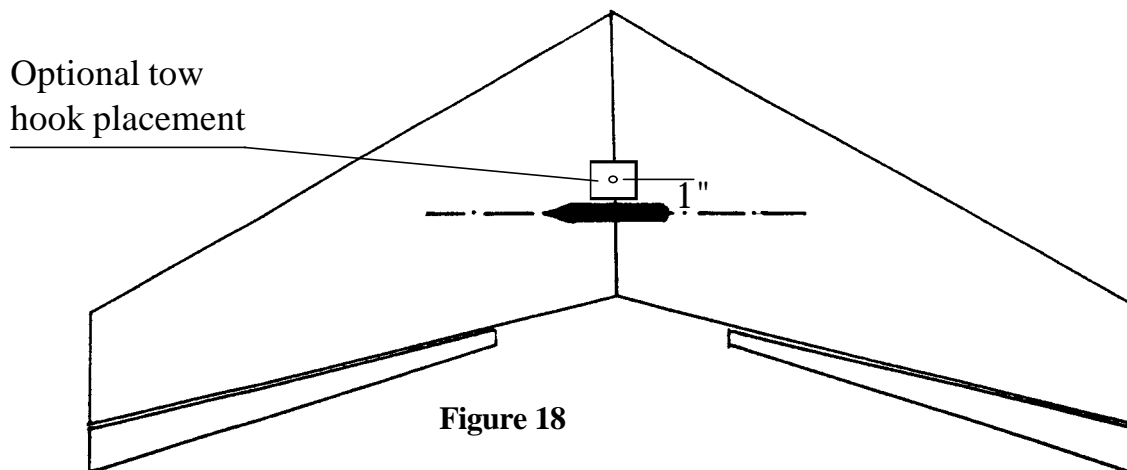

Place the wing right-side-up on a flat surface. Balance is achieved when the wing balances momentarily on the pencil. When the wing stays in either the nose down or nose up position balance is achieved. Add more lead on either side of the lead nose weight if necessary to achieve balance.

Optional hi-start. The Zagi-LE can be launched with a hi-start. Tow hook placement for hi-start should be 1" forward of CG. (See Figure 18) Attach tow hook to a 2" X 2" piece of 1/8" plywood. Tape the assembly to the bottom of the wing so that the hook is 1" forward of CG.



*Chris King launching his Zagi-LE at Pacific Palisades overlooking Malibu California*

# THE LAUNCH

*ZAGI-LE*

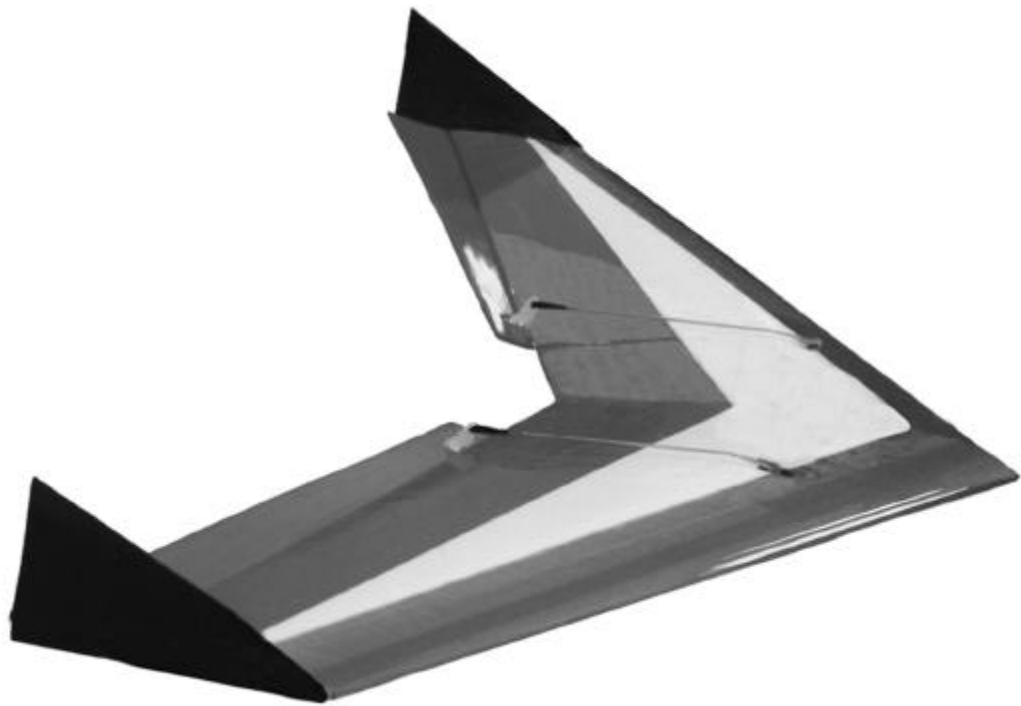

*ZAGI-LE*

